

SCI10F Exam Review

Sample Multiple Choice Questions

I. Reproduction

- Mitosis is
  - the production of gametes.
  - the division of one cell into two genetically identical cells.
  - the production of cells that are genetically unique.
  - the division of one cell into four genetically identical cells.
- Why does mitosis occur?
  - To produce haploid cells
  - To create new and unique genes
  - It enables growth and regeneration.
  - It cuts the number of chromosomes in half.
- A chromosome is
  - a piece of genetic material.
  - found inside all cells.
  - made of DNA.
  - all of the above
- Which of these choices is part of the cell cycle?
  - cell growth
  - DNA replication
  - cell division
  - All of these choices are part of the cell cycle.
- Meiosis is the process of
  - producing gametes.
  - producing genetically identical cells.
  - replacing damaged cells.
  - combining egg and sperm.

6. Male and female gametes are made when a cell divides into

- 2 genetically identical cells.
- 2 genetically different cells.
- 4 genetically identical cells.
- 4 genetically different cells.

7. Which of the following is true?

- Meiosis produces 4 haploid cells and mitosis produces 2 diploid cells.
- Meiosis produces 2 haploid cells and mitosis produces 4 diploid cells.
- Meiosis produces 4 diploid cells and mitosis produces 2 haploid cells.
- Meiosis produces 2 diploid cells and mitosis produces 4 haploid cells.

8. Which of the following is true?

- Meiosis will maintain the same number of chromosomes throughout the process and will make 4 cells.
- Mitosis will maintain the same number of chromosomes throughout the process and will make 4 cells.
- Meiosis will change the number of chromosomes and will make 4 cells.
- Mitosis will change number of chromosomes and will make 4 cells.

Use the following diagram to answer questions 9 and 10.

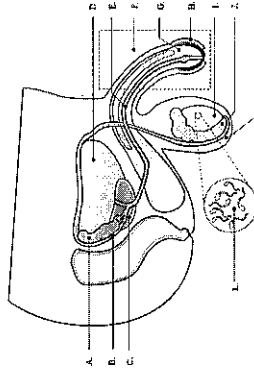

9. What is the name of the structure labeled A?

- urethra
- prostate
- vas deferens
- seminal vesicle

10. What is the name of the structure labeled J?

- A) testicle
- B) bladder
- C) epididymis
- D) sperm

11. What is the function of the testicles?

- A) routing sperm towards the prostate
- B) the production of liquids to protect and nourish sperm
- C) the production of sperm
- D) routing semen to the outside of the body

12. What is the function of the vas deferens?

- A) routing sperm towards the prostate
- B) the production of liquids to protect and nourish sperm
- C) the production of sperm
- D) routing semen to the outside of the body

Use the following diagram to answer questions 13 and 14.

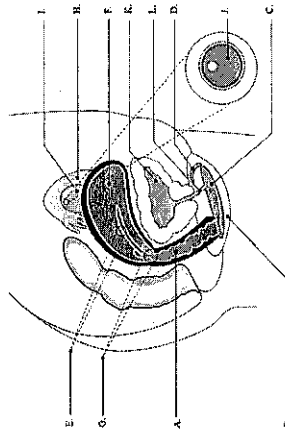

13. What is the name of the structure labeled G?

- A) cervix
- B) vagina
- C) ovum
- D) uterus

14. What is the name of the structure labelled H?

- A) bladder
- B) urethra
- C) fallopian tube
- D) egg

15. What is the function of the uterus?

- A) it is the opening through which the fetus will leave the body of the mother
- B) it is where the eggs are made
- C) it provides the environment for the fertilization of the egg
- D) provides the environment for the development of the fetus

16. What is the function of the vagina?

- A) allows the entry of sperm into the female reproductive system
- B) allows the elimination of urine
- C) it provides nutrients to the fetus
- D) it is where the eggs are stored

17. What is the role of hormones in the male and female reproductive systems?

- A) Hormones fertilize the egg.
- B) Hormones are responsible for triggering reproductive processes such as puberty and menstruation.
- C) Gametes are made of hormones.
- D) The role of hormones is not important in the male and female reproductive systems.

18. The X and Y chromosomes

- A) determine the gender of the baby.
- B) are found in both males and females.
- C) are found only in females.
- D) are only important for sexual traits.

19. An embryo is

- A) another name for a fetus.
- B) the cell formed during fertilization.
- C) the cell that fertilizes the egg.
- D) an organism in its early stage of development.

20. Color blindness is a recessive sex linked trait. Use the pedigree below to answer the following question. What is the genotype of both grandparents?

- A) grandfather =  $X^bX^b$  and grandmother =  $X^bX^b$   
**B) grandfather =  $X^bY$  and grandmother =  $X^bX^b$**   
 C) grandfather =  $X^bY$  and grandmother =  $X^bX^b$   
 D) grandfather =  $X^bY$  and grandmother =  $X^bX^b$

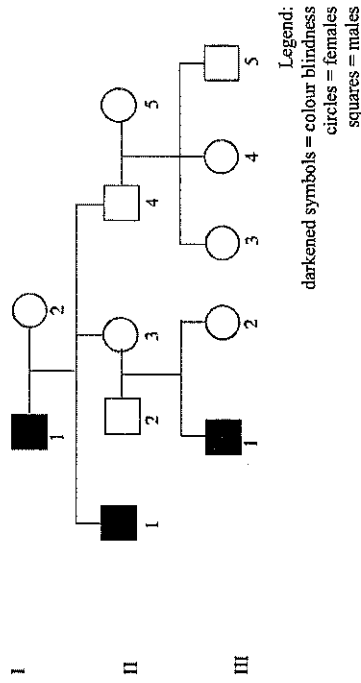

## II. Atoms and Elements

21. What is an element?  
 A) the smallest piece of any substance  
**B) a group of atoms that are all of the same type**  
 C) a mixture of metals  
 D) a mixture of non-metals
22. What is the symbol for potassium?  
 A) Po  
 B) P  
**C) K**  
 D) Kr
23. The atomic number of an element is defined as  
 A) the number of electrons in the atom.  
 B) the number of neutrons in the atom.  
**C) the number of protons in the atom.**  
 D) its weight.
24. The mass of an atom is determined by the number of  
 A) protons in the nucleus.  
 B) electrons in the electron shells.  
**C) protons and neutrons in the nucleus.**  
 D) protons and neutrons in the electron shells.
25. Which element has an atomic number of 4?  
 A) Helium  
**B) Beryllium**  
 C) Titanium  
 D) There is no element with an atomic number 4.
26. Elements that are found in the same family have  
**A) the same number of electrons in their outer shell but have different atomic masses.**  
 B) the same number of protons in the nucleus but have different atomic masses.  
 C) a different number of electrons in the outer shell but have the same atomic masses.  
 D) a different number of protons in the nucleus but have the same atomic masses.

27. Elements that are found in the same period have

- A) the same number of protons in the nucleus but a different number of electron shells.
- B) the same number of electron shells but a different number of protons in the nucleus.**
- C) a different atomic mass and a different number of electron shells.
- D) the same atomic mass but a different number of protons in the nucleus.

28. Which two diagrams represent atoms that belong in the same family?

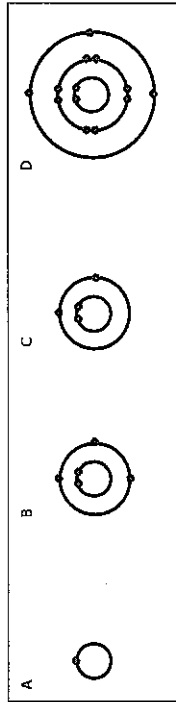

- A) A and B
- B) A and C
- C) B and C
- D) B and D**

29. Which two diagrams from the previous question represent atoms that are part of the same period?

- A) A and B
- B) A and C
- C) B and C**
- D) B and D

30. You discover a new element in space. It is ductile (it can be stretched without breaking) and it is an excellent insulator against heat. In which group would you classify your new element?

- A) metals**
- B) non-metals
- C) metalloids
- D) It is impossible to classify with this information.

31. Which of the following atoms would be the most reactive?

- A) an atom with 1 electron in its outer shell**
- B) an atom with 3 electrons in its outer shell
- C) an atom with 5 electrons in its outer shell
- D) an atom with 6 electrons in its outer shell

32. Which of the following element families is the least reactive?

- A) alkali metals
- B) alkaline earth metals
- C) chalcogens
- D) noble gases**

33. Which statement best describes atoms and molecules?

- A) Atoms are indivisible particles of matter and molecules are the smallest particles of a pure substance.
  - B) Atoms are indivisible particles of matter and molecules groups of the same types of atoms.
  - C) Atoms and molecules are the same thing.
  - D) Molecules are indivisible particles of matter and atoms are the smallest particles of a pure substance.
- no correct answers*

34. What elements make up the chemical formula for baking soda:  $\text{NaHCO}_3$ ?

- A) Nitrogen, Hydrogen, Carbon and Oxygen
- B) Nitrogen, Aluminum, Hydrogen and Cobalt
- C) Sodium, Hydrogen and Cobalt
- D) Sodium, Hydrogen, Carbon and Oxygen**

35. How many atoms are there in 3 molecules of carbon dioxide:  $3\text{CO}_2$ ?

- A) 3
- B) 4
- C) 6
- D) 9**

### III. The Nature of Electricity

36. When you are shocked by static electricity, what happens to the charge that passes through you?

- A) It is used up and it disappears.
- B) It is transferred to the ground.**
- C) It stays in you for ever.
- D) None of the above.

37. Conduction can be described as a charge

- A) moving through an object and into another.**
- B) accumulating in an insulator.
- C) that is redistributed within an object to create opposite charges.
- D) that is used up and disappears.

38. Why is a neutral insulator attracted to charged objects?

- A) The neutrons in an insulator can become negative or positive.
- B) The protons in an insulator can be attracted to either a negative or a positive object.
- C) The charged object will be attracted to either the protons or the electrons in the neutral insulator.**
- D) The electrons in an insulator can be attracted to either a negative or a positive object.

39. A neutral conducting sphere is charged by induction using a positively charged balloon, as shown in the following diagram. What charge will be left on the sphere at the end of step e?

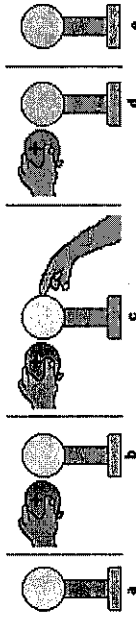

- A) positive
- B) negative**
- C) neutral
- D) It is impossible to determine charge using this information.

40. What is current?

- A) the quantity of charge per unit of time**
- B) the intensity of current per unit of time
- C) the amount of energy per unit of charge
- D) the amount of energy per unit of time

41. An iPod uses 1.5 coulombs in one second. Calculate the current used by an iPod.

- A) 0.67 amperes
- B) 1.5 amperes**
- C) 0.67 volts
- D) 1.5 volts

42. When there is an electric current passing through a wire, the particles that are moving are

- A) electrons.**
- B) protons.
- C) neutrons.
- D) ions.

43. The current in a wire

- A) depends only on the voltage applied.
- B) depends only on the resistance of the wire.
- C) depends on both the voltage applied and the resistance of the wire.**
- D) does not depend on either the voltage applied or the resistance of the wire.

44. Electric potential difference (voltage) is

- A) the quantity of charge per unit of time.
- B) the intensity of the charge between two points along a conductor.
- C) the amount of energy per unit of time.
- D) the energy per unit of charge between two points along a conductor.**

45. The potential difference (voltage) between the two poles of a battery is 12 V. Calculate the quantity of charge that passes through the battery if 240 J of energy was consumed.

- A) 240 C
- B) 20 C**
- C) 12 C
- D) 0.05 C

46. Electromagnetic energy is

- A) what's found in electrochemical batteries.
- B) the transformation of magnetic energy into electricity.**
- C) created when the Sun's energy is changed into electricity.
- D) the transformation of heat energy into electricity.

47. Resistance is

- A) the movement of charge.
- B) quantity of charge per unit of time.
- C) the opposition to the movement of charge.
- D) the energy per unit of charge between two points along a conductor.

48. Which of the following diagrams shows 2 batteries positioned properly in parallel? (all bulbs are identical)

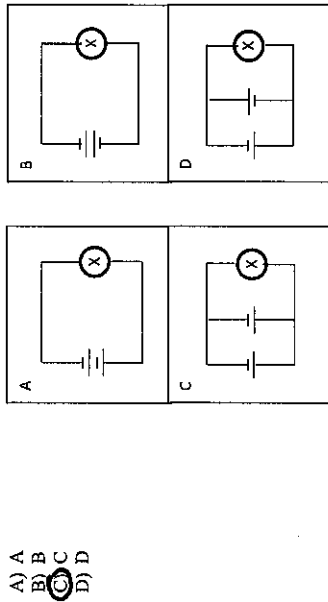

- A) A
- B) B
- C) C
- D) D

49. Which of the following diagrams shows an ammeter that will properly measure the current passing through the bulb? (all bulbs and batteries are identical)

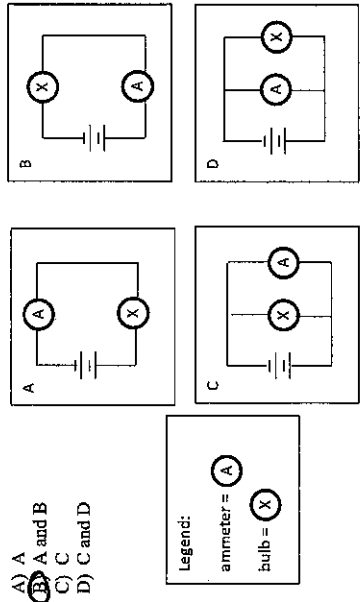

- A) A
- B) A and B
- C) C
- D) C and D

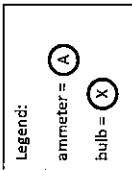

50. In which of the following circuits would the light bulbs be the brightest? (all bulbs and batteries are identical)

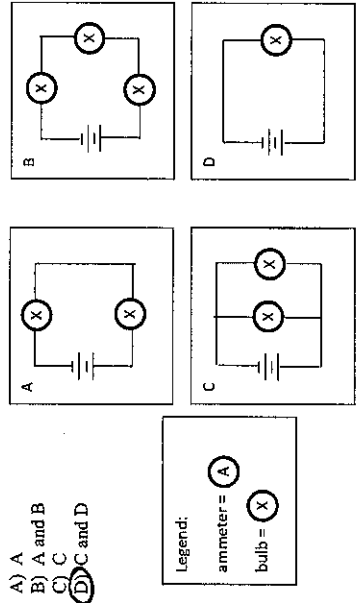

- A) A
- B) A and B
- C) C
- D) C and D

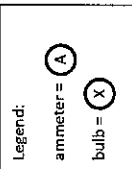

51. What instrument is used to measure resistance?

- A) an ammeter
- B) an ohmmeter
- C) a voltmeter
- D) a resistor

52. In a circuit with a constant voltage,

- A) an increase in resistance will reduce the current.
- B) an increase in resistance will increase the current.
- C) the current will also remain constant regardless of any adjustment in the resistance.
- D) the resistance will also remain constant regardless of any adjustment in the resistance.

53. What is electrical power?

- A) energy per unit of time
- B) current per unit of time
- C) energy per quantity of charge
- D) current per quantity of charge

54. If the rate of electrical power is \$0.075/kWh, calculate the cost of using a 1.5 kW space heater over a period of 100 days when it is used 10 hours a day.

- A) \$50.00
- B) \$112.50
- C) \$20,000.00
- D) \$5.00

55. What is the reading of the following electrical meter?



- A) 65237
- B) 7.3, 3.2, 2.5, 5.6, 6.7
- C) 84367
- D) 73256

#### IV. Exploring the Universe

56. Choose the best answer. A celestial object can be seen at exactly  $90^\circ$  azimuth. Where are you looking?

- A) to the north
- B) straight up above your head
- C) to the east
- D) right on the horizon

57. A celestial object can be seen at exactly  $90^\circ$  altitude. Where are you looking?

- A) to the north
- B) straight up above your head
- C) to the east
- D) right on the horizon

58. When ancient astronomers were mapping the sky, they discovered that some celestial objects seemed to wander back and forth in their year long journey. This type of motion is known as

- A) star motion
- B) retrograde motion
- C) comet motion
- D) regular motion

59. Some constellations are only visible during certain times of the year. This is due to

- A) the distance of the Earth to the Sun.
- B) the diameter of the Earth.
- C) the tilt of the Earth's axis.
- D) the movement of the constellations.

60. The reason the Moon appears to rise and set just like to Sun is that

- A) the Earth is rotating on its axis.
- B) the Moon is revolving around the Earth.
- C) the Earth is revolving around the Sun.
- D) the Earth's atmosphere is creating an optical illusion.

61. Stars appear to revolve slowly around the North Star. This is caused by

- A) the movement of the stars.
- B) the fact that the Earth's axis is pointing at the North Star.
- C) the rotation of the Earth
- D) both B) and C)

62. If it take exactly 15 years for the light of a star to reach the Earth, how far away is that star from Earth?

- A) 15 astronomical units
- B) 15 light years
- C) 15 x 365 astronomical units
- D) 15 x 365 light years

63. \_\_\_\_\_ revolve around \_\_\_\_\_ which revolve around \_\_\_\_\_.

- A) Moons, black holes, nebulae
- B) Comets, stars, planets
- C) Moons, planets, stars
- D) Comets, asteroids, planets

64. This component of the universe has enormous gravity, is created when a star implodes and can't be seen with the naked eye.

- A) comets
- B) nebulae
- C) astronomical units
- D) black holes

65. This very large celestial object is composed of gas and dust is created when a star explodes.

- A) nebulae
- B) asteroids
- C) galaxies
- D) comets



SC10F Exam Review

Sample Extended Answer Questions

1. Reproduction

1. The diagram below shows the 4 stages in the process of mitosis. For the first and third stage, complete the diagram by sketching the contents of the cell as they would appear during those stages.

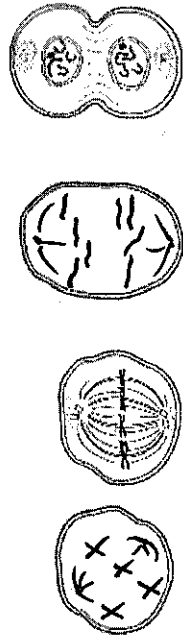

2. Choose one of the following types of asexual reproduction. Describe the method you have chosen and give an example of an organism that uses that type of reproduction.

fission budding sporulation vegetative propagation regeneration

① fission - cell with no nucleus makes a copy of its one chromosome, then divides (e.g. bacteria)

② budding - new organism grows on parent and detaches when mature (e.g. hydra)

③ sporulation - organism releases lots of tiny cells called spores, each grows into new individual (e.g. mold)

④ veg. prop. - asexual reproduction of a plant by layering, grafting etc. (e.g. raspberry bush)

⑤ regen - regrow lost body part (e.g. starfish)

3. Describe ONE agricultural application of asexual reproduction. You may choose to describe one of the following applications or any other application of your choice: cloning, cuttings, grafting, bulbs.

① cloning - making an exact copy of a plant

② cutting - cut off a piece of a plant and use it to grow new plants.

③ grafting - attach branch of one plant to trunk of another

④ bulb - cut bulb off plant and use to grow new plants

4. Give one advantage and one disadvantage each for sexual reproduction and asexual reproduction.

	Advantage	Disadvantage
Asexual Reproduction	<ul style="list-style-type: none"> <li>fast</li> <li>less energy</li> </ul>	<ul style="list-style-type: none"> <li>slow to adapt</li> </ul>
Sexual Reproduction	<ul style="list-style-type: none"> <li>slow</li> <li>more energy</li> </ul>	<ul style="list-style-type: none"> <li>quick to adapt</li> </ul>

5. Explain *ONE* adaptation of a plant or an animal species which improves its chances of successful reproduction. You may choose to describe one of the following adaptations or any other adaptation of your choice: appearance, behaviour, number of gametes or offspring, chemical cues.

answers vary  
 e.g. male birds have colorful feathers to attract females

6. "R" represents the gene that gives you the ability to roll your tongue while "r" represents the gene that disrupts your ability to roll your tongue. Jack and Jill had a son who can roll his tongue and a daughter who can't roll her tongue. Give the genotypes and the phenotypes of all four family members. Show your work.

There are 4 possible answers:

Jack Rr Rr rr Rr Rr  
 Jill Rr rr Rr Rr  
 Son RR Rr Rr Rr  
 Daughter rr rr rr rr

Pick one and show the Punnett Square that justifies your answer.

## II. Atoms and Elements

7. Fill in the following table so that it properly describes the characteristics of protons, electrons and neutrons.

Sub-atomic particle	Mass (small or large)	Position in the atom (nucleus or orbit)	Charge (+1, -1 or neutral)	Determines the type of atom (yes or no)
Proton	L	n	+1	y
Electron	S	o	-1	n
Neutron	L	n	0	n

8. Draw the Bohr model for Magnesium. Label the nucleus and the electron shells. Be sure to include the correct number of protons, electrons, and neutrons in your diagram.

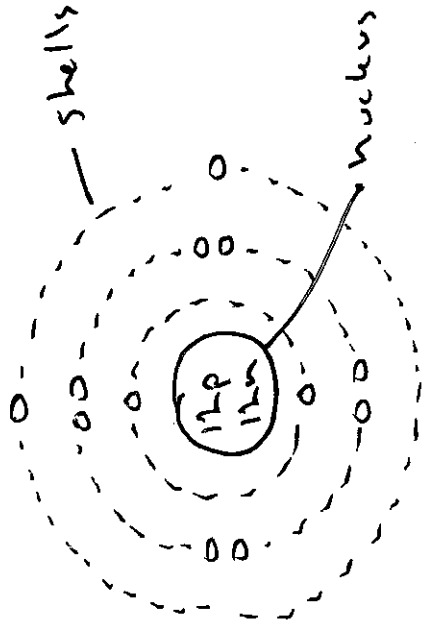

9. What is special about the atomic structure of all halogens?

all have seven valence electrons.

### III. Electricity

12. What do atoms have to do with electricity? Talk about the subatomic particles to explain your answer.

movement or transfer of electrons = electricity

10. Explain the difference between a chemical change and a physical change.

Chemical change	Physical change
new substance formed	no new substance formed

11. State two indicators of a chemical change.

Indicator 1 gas produced	Indicator 2 color change
-----------------------------	-----------------------------

13. Add "+" and "-" signs in the drawing below to explain why a balloon that was rubbed on someone's head is sticking to the neutral wall. Include an explanation for your answer in the space below.

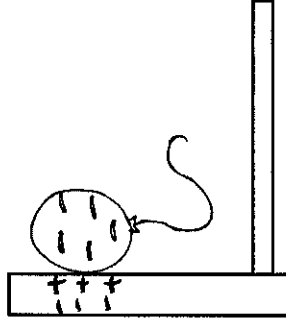

The - charges in the balloon create a charge separation in the wall. The balloon is then attracted to the + side of the wall.

14. Explain how static electricity and electrical current are similar.

both involve electrons

IV. Astronomy

17. The position and motion of visible celestial objects was very important for various cultures throughout history. Name one historical importance.

- navigation
- predicting the future
- calendar

15. Choose one of the following sources of electrical energy. Describe it and give an example of an associated technology. Choose ONE: chemical, photo, thermo, electromagnetic or piezo.

chemical - convert chemical → electrical  
(e.g. battery)

photo - light → electrical (e.g. solar panel)

thermo - heat → electrical (thermocouple)

electro - magnetism → electrical (generator)

piezo - vibrating crystal → elect. (microphone)

16. Draw two different circuits, one in each of the boxes below.

Your drawings must meet the following criteria:

- Each circuit must have 2 bulbs and 1 battery.
- The circuit in Box A must have a higher current than the circuit in Box B. (Assume that all batteries and bulbs are identical.)

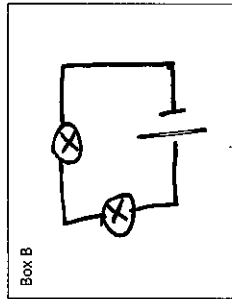
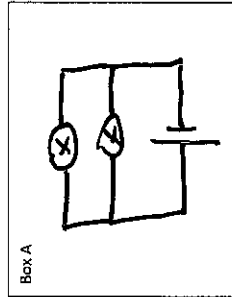

18. Compare the geocentric and heliocentric models of the universe by doing ONE of the following:

- write a short paragraph, OR
- draw a labeled diagram of each model

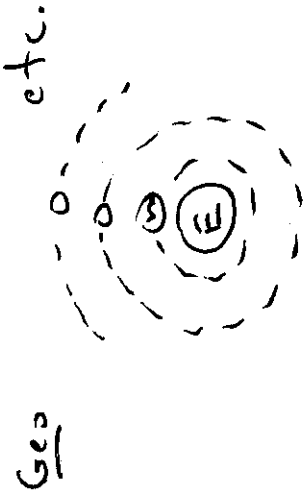

show full diagram